

DIAMOND / CBN
GRINDING WHEELS

SAW / KNIFE GRINDING
APPLICATIONS

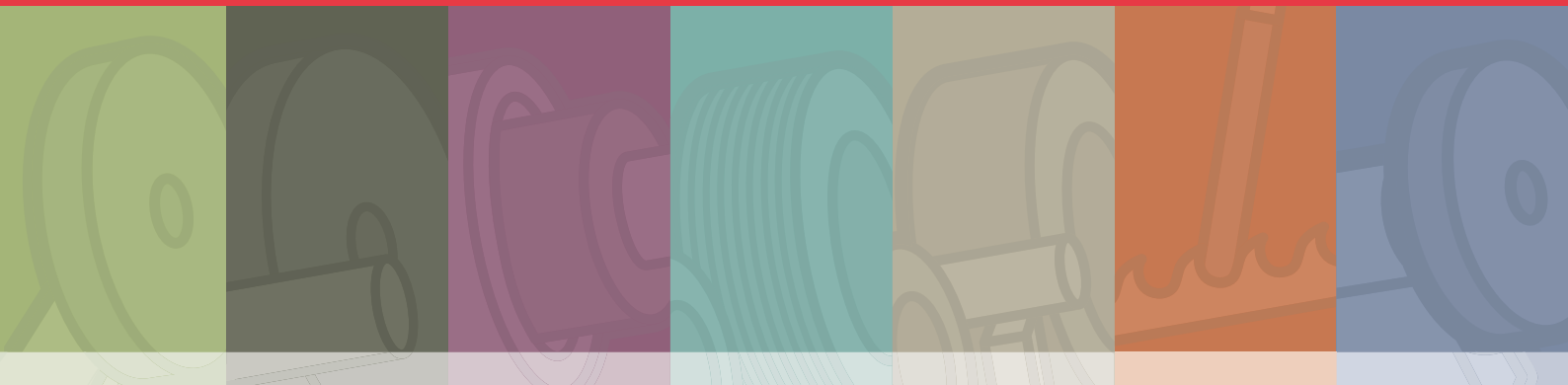

 **molemab**[®]
we shape your world

we shape your world

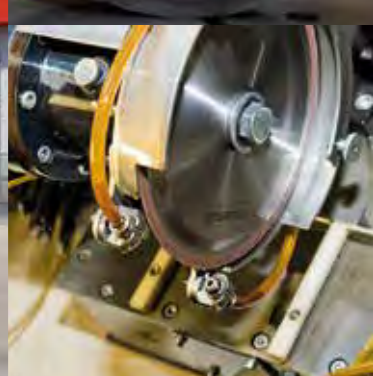

-  POWER THROUGH INNOVATION
-  DEVELOPMENT IN DIALOG WITH THE CUSTOMERS
-  HIGH FLEXIBILITY
-  CUSTOMER-ORIENTED SERVICE

Table of contents

Company presentation	2
Saw grinding	3
Machines:	
Akemat	4-6
Reform	7
Göckl	7
Metal circular saw	8
Schmidt Tempo	8
Vollmer Biberach	9-12
Vollmer Dornhan	13-16
Walter	17-20
Weinig	21-22
Iseli	23-24

Welcome to the world of
precision grinding wheels



GET IN SHAPE WITH US

We are a competent manufacturer of Diamond and CBN grinding wheels with many years of experience in this area.

Using our technical Know How and our high quality products, we help our customers in close cooperation to increase their productivity.

A high degree of flexibility along with our ability to adapt to customer requirements and a customer orientated service differentiates us from many competitors.

Your Molemab Team

Saw grinding



Face grinding



Side grinding

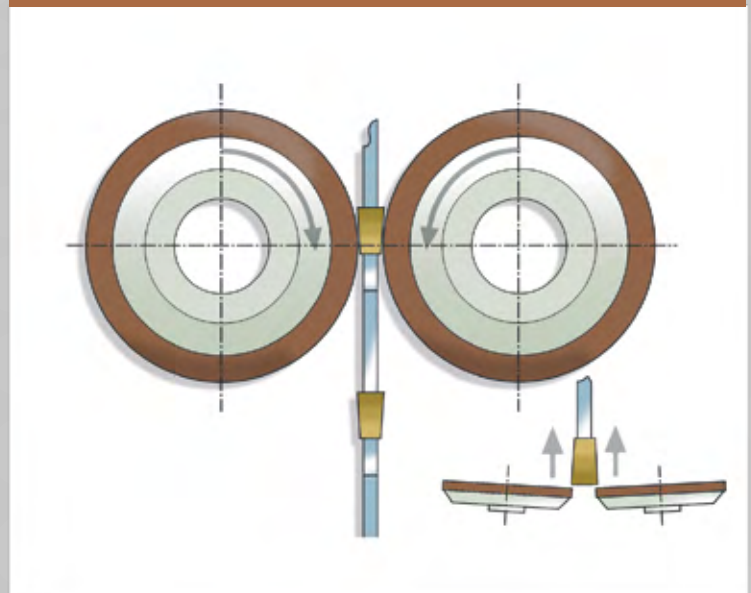

Back grinding





Akemat B



4B9-832

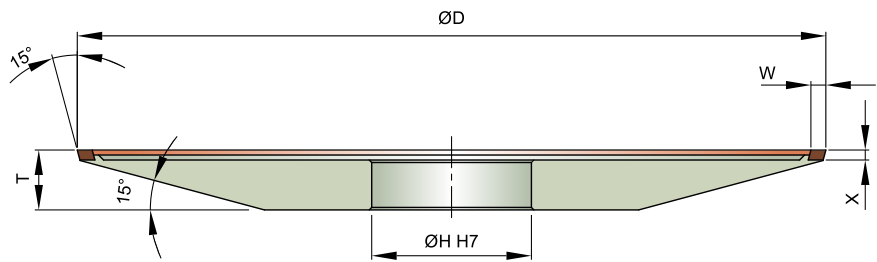

Shape	D	W	X	H	T
4B9-832	150	3	2	32	12

Order specimen:

Shape	Dimension	Quality
4B9-832	D-W-X-H: 150-3-2-32	D54 R75 BW361 Y A

Akemat B

4V2-842

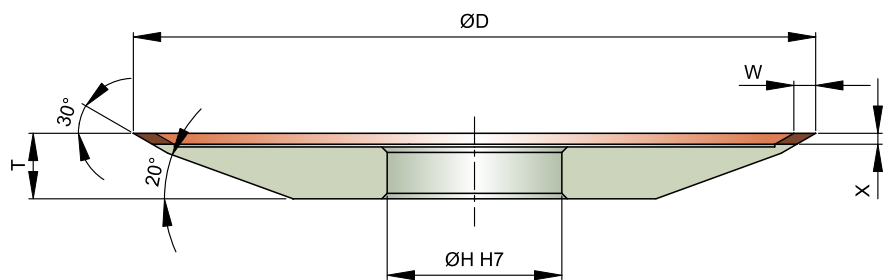

Shape	D	W	X	H	T
4V2-842	150	4	2	32	13

Order specimen:

Shape	Dimension	Quality
4V2-842	D-W-X-H: 150-4-2-32	D76 R125 BW361 Y A

Akemat U6 R2

4V2-042

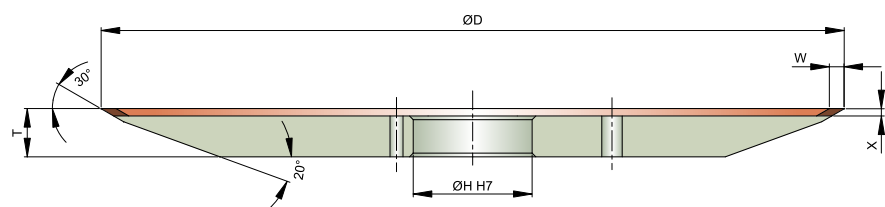

Shape	D	W	X	H	T
4V2-042	200	4	2	32	13

Order specimen:

Shape	Dimension	Quality
4V2-042	D-W-X-H: 200-4-2-32	D76 R125 BW361 Y A



Akemat B



12V9-22°

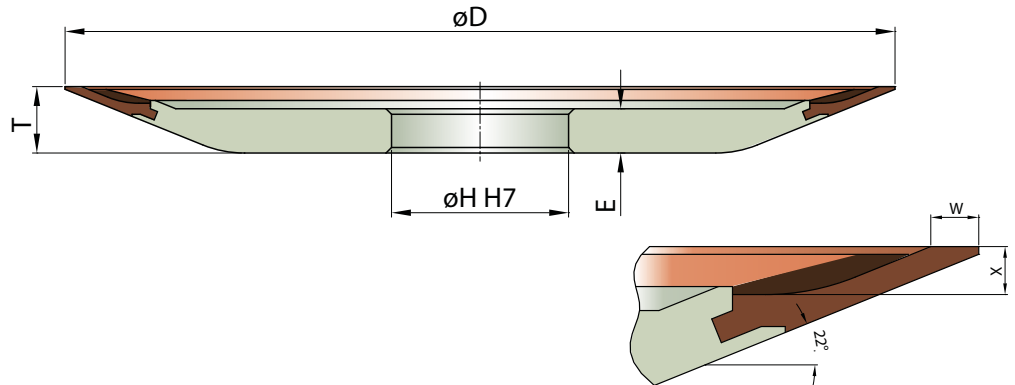

Shape	D	W	X	H	T	E
12V9-22°	150	3	3	32	12	10

Order specimen:

Shape	Dimension	Quality
12V9-22°	D-W-X-H: 150-3-3-32	D64 R125 BW361 Y A

Akemat U6 R2

12V9-22°

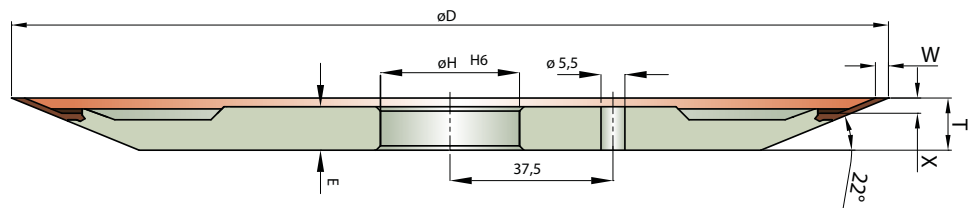

Shape	D	W	X	H	T	E
12V9-22°	200	3	3	32	12	10

Order specimen:

Shape	Dimension	Quality
12V9-22°	D-W-X-H: 200-3-3-32	D64 R125 BW361 Y A

Akemat

1A8W

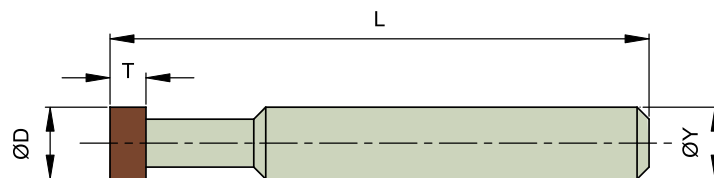

Shape	D	T	X	Y	L
1A8W	6.5	3	1.75	6	45
1A8W	6.5	6	1.75	6	48

Order specimen:

Shape	Dimension	Quality
1A8W	D-T-X-Y: 6.5-3-1.75-6	D64 R125 BW361 Y E



Akemat U, UR R2



Back grinding

14B1-757

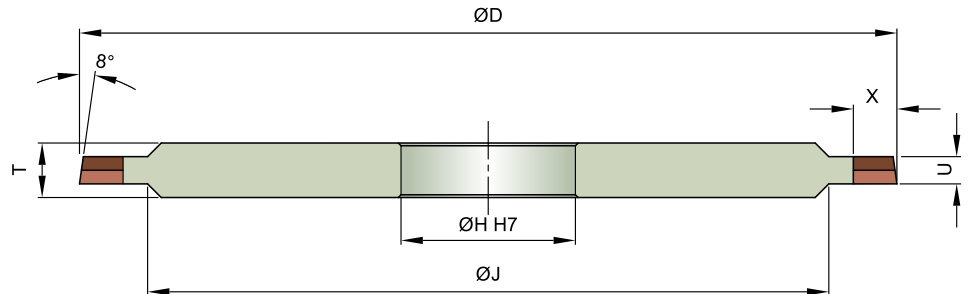

Shape	D	U	X	H	T	J
14B1-757	127	5	7	32	8	100

Order specimen:

Shape	Dimension	Quality
14B1-757	D-W-X-H: 127-5-7-32	D126/46 R100/75 BW361 Y A/BW356 Y A

Akemat F

Side grinding

62B9-545 62B9-645

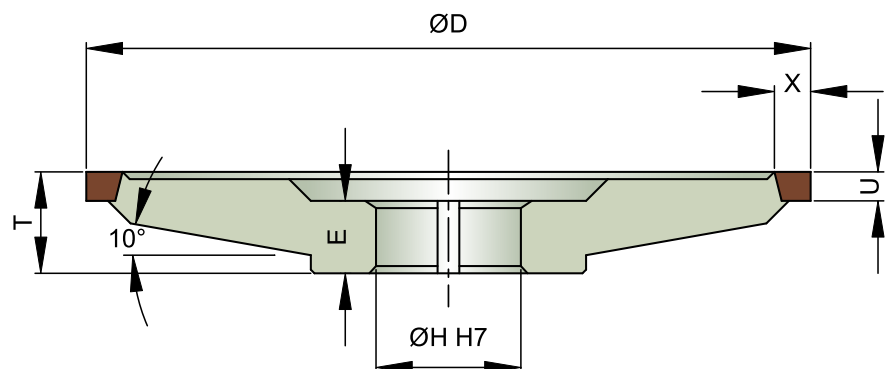

Shape	D	U	X	H	T	E
62B9-545	75	4	5	20	14	10
62B9-645	100	4	5	20	14	10

Order specimen:

Shape	Dimension	Quality
62B9-645	D-U-X-H: 100-4-5-20	D91 R75 BW356 Y A



Reform

6A2

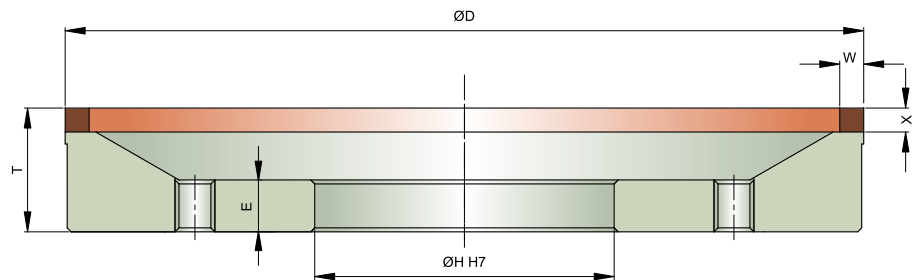

Shape	D	W	X	H	T	E
6A2-066	200	6	6	75	31	13
6A2-060	200	6	10	75	35	13
6A2-086	200	8	6	75	31	13
6A2-B66	250	6	6	75	31	13
6A2-B60	250	6	10	75	35	13
6A2-B86	250	8	6	75	31	13

Order specimen:

Shape	Dimension	Quality
HM 6A2-066	D-W-X-H: 200-6-6-75	D76 R75 BW261 Y A
HSS 6A2-066	D-W-X-H: 200-6-6-75	B151 R75 BT966 Y A

Göckel

6A2

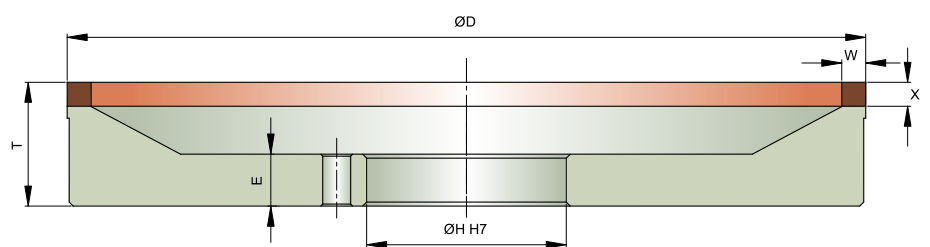

Shape	D	W	X	H	T	E
6A2-066	200	6	6	50	31	13
6A2-060	200	6	10	50	35	13
6A2-086	200	8	6	50	31	13
6A2-B66	250	6	6	50	31	13
6A2-B60	250	6	10	50	35	13
6A2-B86	250	8	6	50	31	13

Order specimen:

Shape	Dimension	Quality
HM 6A2-066	D-W-X-H: 200-6-6-50	D76 R75 BW261 Y A
HSS 6A2-066	D-W-X-H: 200-6-6-50	B151 R75 BT966 Y A



Metal circular saw - Schmidt-Tempo

Standard

TS (H32)

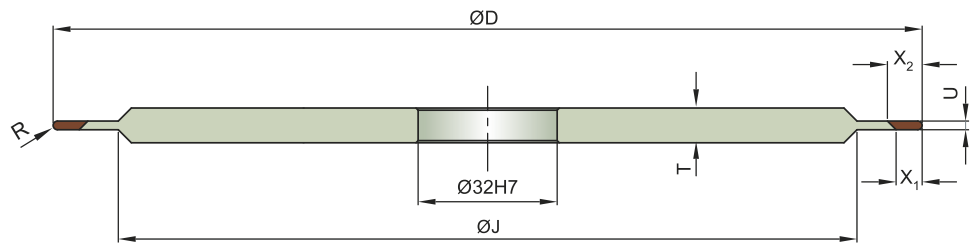

Shape	D	U	X(=X1)	X2	H	T	J	R
TS (H32)	200	1.3	4	6	32	8	188	
TS (H32)	200	1.6	6	8	32	8	170	
TS (H32)	200	2	6	8	32	8	165	
TS (H32)	200	2.5	6	8	32	8	165	U/2
TS (H32)	200	3	6	10	32	8	160	
TS (H32)	200	3.5	8	12.5	32	8	160	
TS (H32)	200	4	8	12.5	32	8	155	

Order specimen:

Shape	Dimension	Quality
TS	D-U-X-H: 200-3-6-32	B107 AB35 E

Schmidt Tempo



TS (H20)

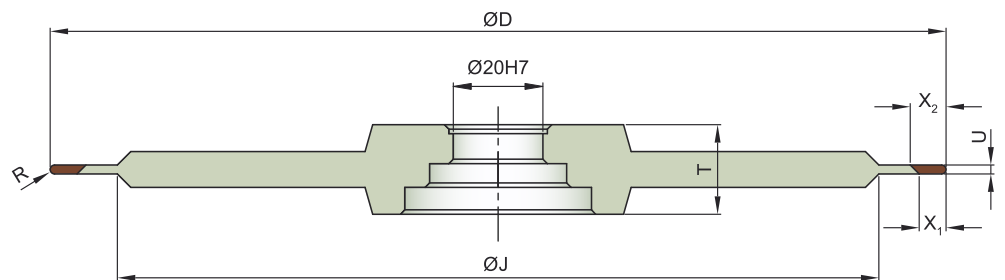

Shape	D	U	X(=X1)	X2	H	T	J	R
TS (H20)	150	1.3	4	6	20	20	138	
TS (H20)	150	1.6, 2, 2.5	6	8	20	20	120	
TS (H20)	150	3	6	10	20	20	115	
TS (H20)	150	3.5, 4	8	12.5	20	20	105	
TS (H20)	200	1.3	4	6	20	20	188	
TS (H20)	200	1.6	6	8	20	20	170	U/2
TS (H20)	200	2, 2.5	6	8	20	20	165	
TS (H20)	200	3	6	10	20	20	160	
TS (H20)	200	3.5	8	12.5	20	20	160	
TS (H20)	200	4	8	12.5	20	20	155	

Order specimen:

Shape	Dimension	Quality
TS	D-U-X-H: 200-3-6-20	B107 AB35 E



Vollmer Biberach



4V2-642

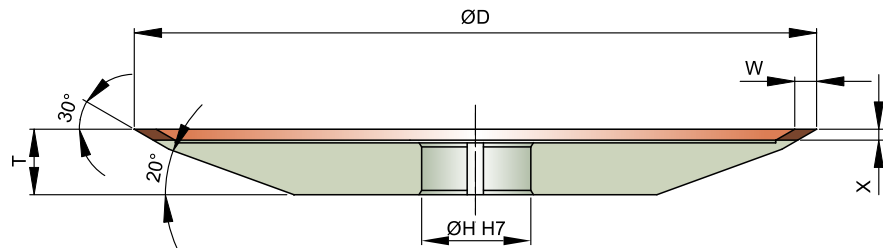

Shape	D	W	X	H	T	Machinetype
4V2-642	100	4	2	25	10	Unimat S

Order specimen:

Shape	Dimension	Quality
4V2-642	D-W-X-H: 100-4-2-25	D76 R125 BW361 Y A

Vollmer Biberach

4V2-742

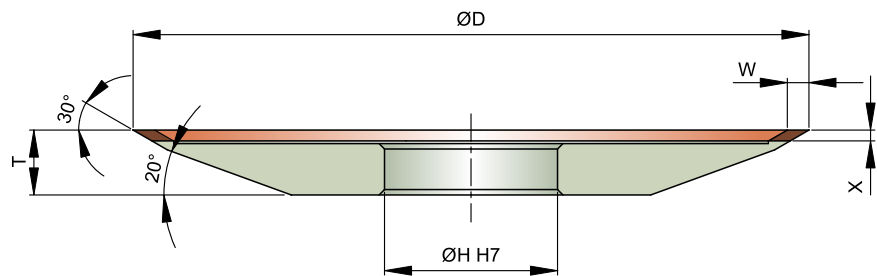

Shape	D	W	X	H	T	Machinetype
4V2-742	125	4	2	32	12	CHC,CHCB,CHP,CE,CEP,CEN,CHM

Order specimen:

Shape	Dimension	Quality
4V2-742	D-W-X-H: 125-4-2-32	D76 R125 BW361 Y A

Vollmer Biberach

4V2-042

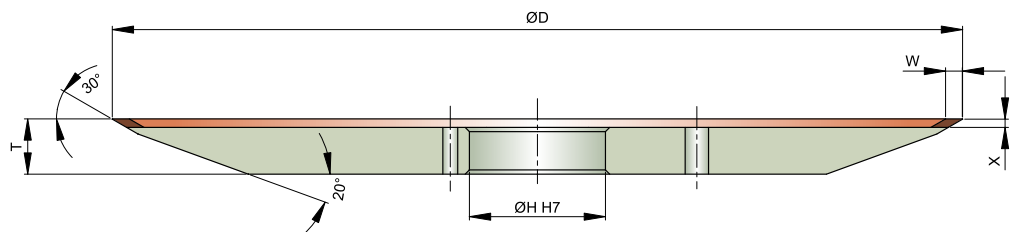

Shape	D	W	X	H	T	Machinetype
4V2-042	200	4	2	32	13	CHD, Service Center

Order specimen:

Shape	Dimension	Quality
4V2-042	D-W-X-H: 200-4-2-32	D76 R125 BW361 Y A



Vollmer Biberach



12V9-22°

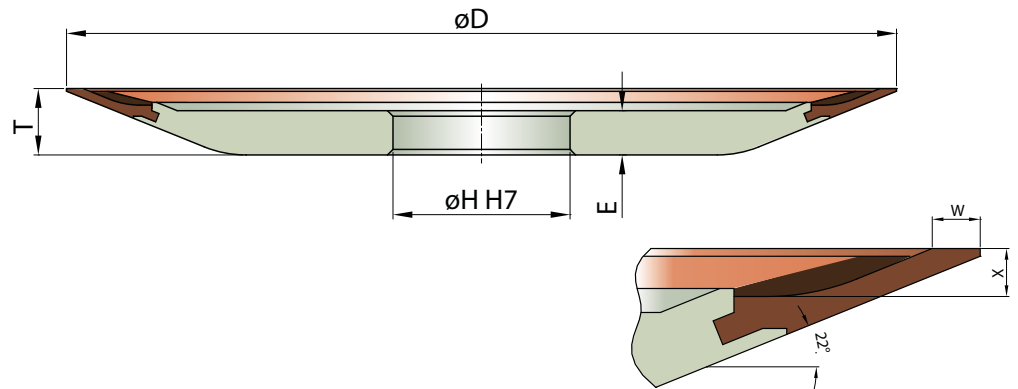

Shape	D	W	X	H	T	E	Machinetype
12V9-22°	125	3	3	32	12	8	CHC, CHCB, CHP, CE, CEP, CEN, CHM, CB, CC, CHT, CHHT, CNHB, CHTS, CX

Order specimen:

Shape	Dimension	Quality
12V9-22°	D-W-X-H: 125-3-3-32	D76 R125 BW361 Y A

Vollmer Biberach

12V9-22°

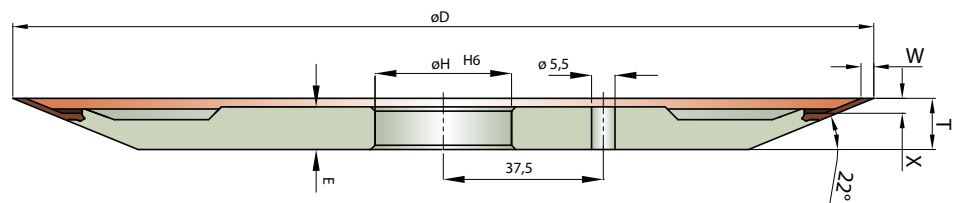

Shape	D	W	X	H	T	E	Machinetype
12V9-22°	200	3	3	32	12	10	CHD, Service Center

Order specimen:

Shape	Dimension	Quality
12V9-22°	D-W-X-H: 200-3-3-32	D76 R125 BW361 Y A



Vollmer Biberach



1A8W

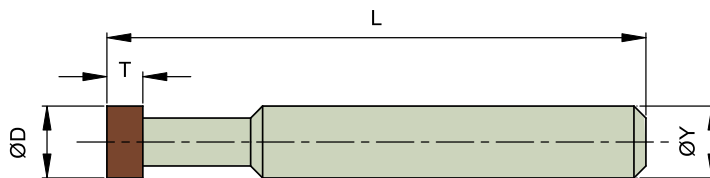

Shape	D	T	X	Y	L
1A8W	6.5	3	1.75	6	45
1A8W	6.5	6	1.75	6	48

Order specimen:

Shape	Dimension	Quality
1A8W	D-T-X-Y: 6.5-3-1.75-6	D64 R125 BW361 Y E

Vollmer Biberach

6AV5-756
6AV5-750

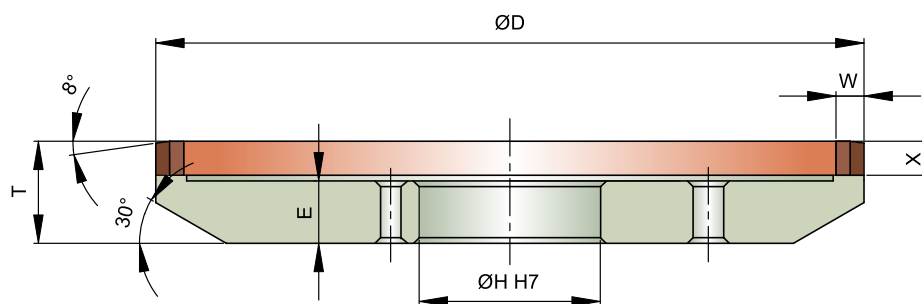

Shape	D	W	X	H	T	Machinetype
6AV5-756	125	5	6	32	20	CHC, CHP, CEP, CEN, CHM, CB, CC, CHHT, CHD, CX, Service Center
6AV5-750	125	5	10	32	24	Center

Order specimen:

Shape	Dimension	Quality
6AV5-750	D-W-X-H: 125-5-10-32	D126/46 R100/75 BW361 Y I/BW356 Y I



Vollmer Biberach



11B9-763

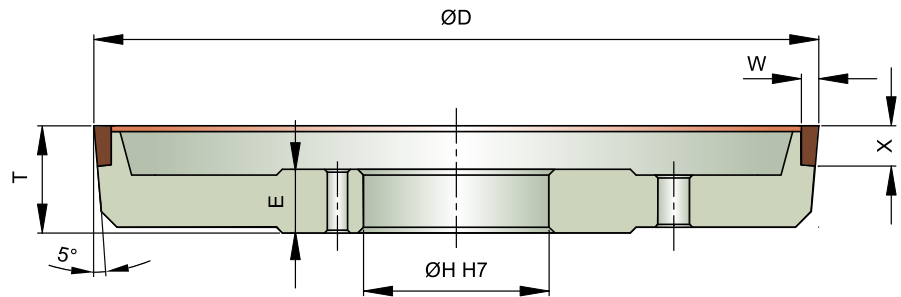

Shape	D	W	X	H	T	Machinetype
11B9-763	125	3	6.5	32	18	CC, CB, CE, CHC, CHO, CEP, CEN, CHM, CHT, CHTS, CHHT, CX

Order specimen:

Shape	Dimension	Quality
11B9-763	D-W-X-H: 125-3-6.5-32	D76 R125 BW361 Y A

Vollmer Biberach

60B9-645

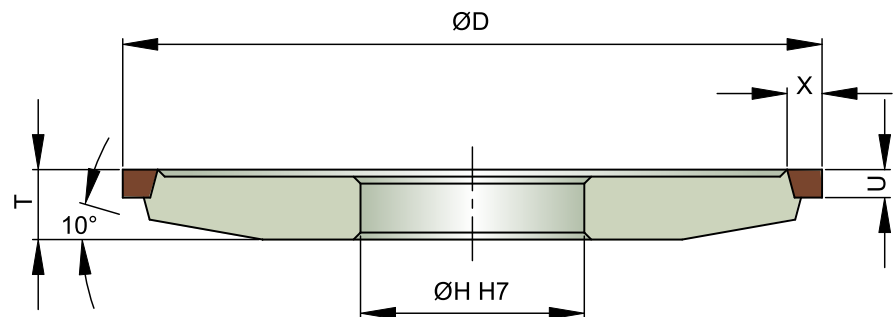

Shape	D	U	X	H	T	Machinetype
60B9-645	100	4	5	32	10	CC, CEF, CFL, CHAFT, CHFTE, CH, HF, CHTF, CHF, FS

Order specimen:

Shape	Dimension	Quality
60B9-645	D-U-X-H: 100-4-5-32	D91 R75 BW361 Y A

Back grinding

Side grinding



Vollmer Dornhan



4V2-642

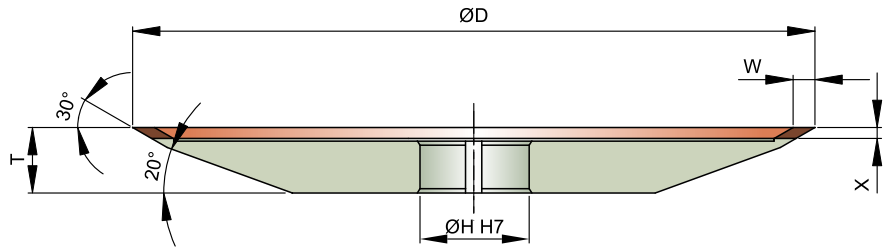

Shape	D	W	X	H	T	Machinetype
4V2-642	100	4	2	25	10	Unimat S

Order specimen:

Shape	Dimension	Quality
4V2-642	D-W-X-H: 100-4-2-25	D76 R125 BW361 Y A

Vollmer Dornhan

4V2-742

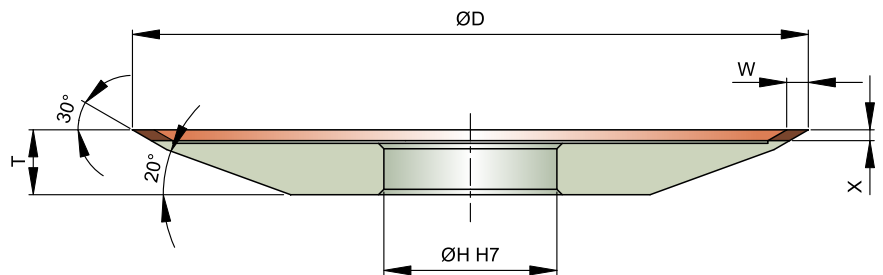

Shape	D	W	X	H	T	Machinetype
4V2-742	125	4	2	32	12	CHC,CHCB,CHP,CE,CEP,CEN,CHM

Order specimen:

Shape	Dimension	Quality
4V2-742	D-W-X-H: 125-4-2-32	D76 R125 BW361 Y A



Vollmer Dornhan



4V2-942

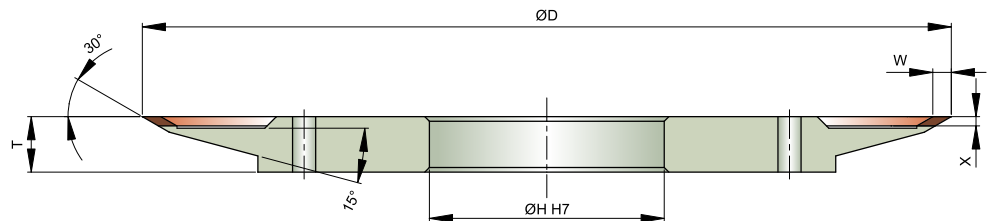

Shape	D	W	X	H	T	Machinetype
4V2-942	175	4	2	50.8	12	DLA Alfa, Beta, Gamma

Order specimen:

Shape	Dimension	Quality
4V2-942	D-W-X-H: 175-4-2-50.8	D76 R125 BW361 Y A

Vollmer Dornhan

4A2

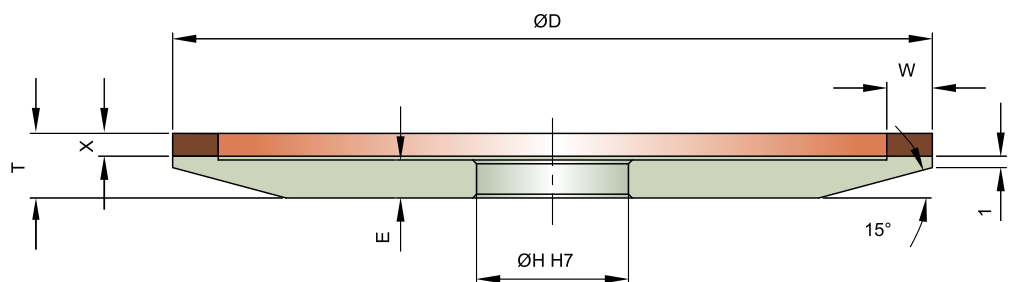

Shape	D	W	X	H	T	E
4A2	100	3	2	25	8	5.5
4A2	100	4	2	25	8	5.5

Order specimen:

Shape	Dimension	Quality
4A2	D-W-X-H: 100-3-2-25	D64 R125 BW361 Y A



Vollmer Dornhan



12V9-22°

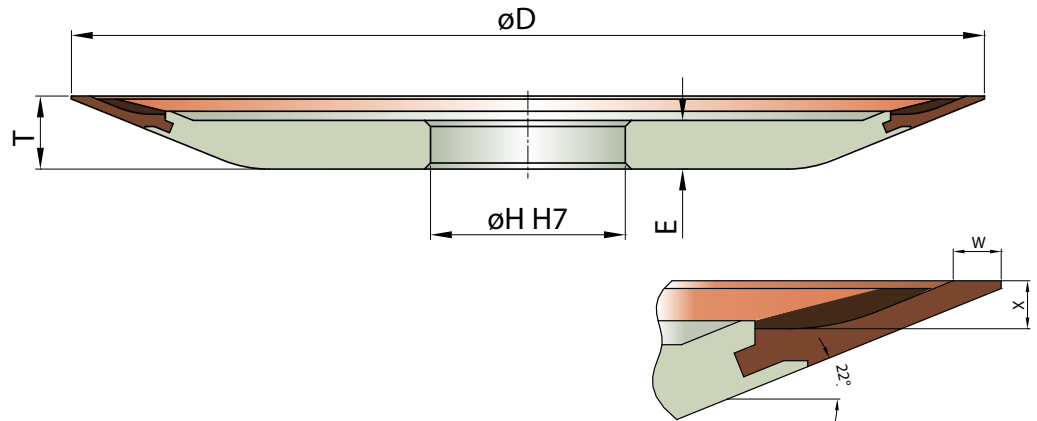

Shape	D	W	X	H	T	E
12V9-22°	125	3	3	32	12	8

Order specimen:

Shape	Dimension	Quality
12V9-22°	D-W-X-H: 125-3-3-32	D64 R125 BW361 Y A

Vollmer Dornhan

4B9-632

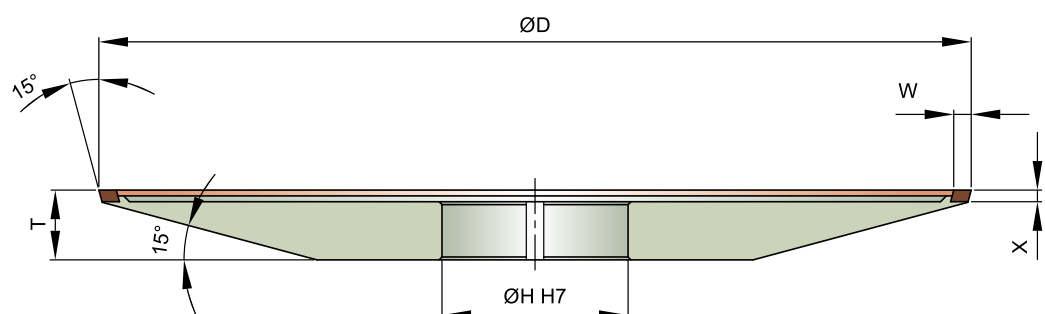

Shape	D	W	X	H	T
4B9-632	100	3	1.8	25	8

Order specimen:

Shape	Dimension	Quality
4B9-632	D-W-X-H: 100-3-1.8-25	D64 R125 BW361 Y A



Vollmer Dornhan - Machine

Vollmer Dornhan



6AV5-656
6AV5-650

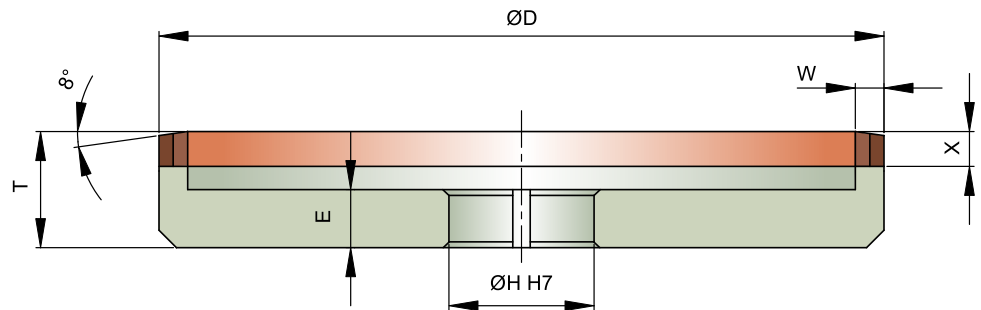

Shape	D	W	X	H	T	E
6AV5-656	100	5	6	25	20	8
6AV5-650	100	5	10	25	24	8

Order specimen:

Shape	Dimension	Quality
6AV5-650	D-W-X-H: 100-5-10-25	D126/46 R100/75 BW360 Y I/BW360 Y I

Vollmer Dornhan

62B9-545
62B9-645

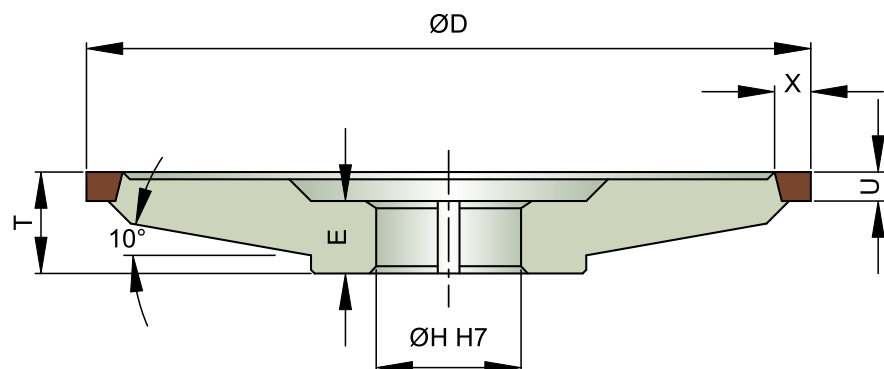

Shape	D	U	X	H	T	E
62B9-545	75	4	5	20	14	10
62B9-645	100	4	5	20	14	10

Order specimen:

Shape	Dimension	Quality
62B9-645	D-U-X-H: 100-4-5-20	D91 R75 BW356 Y A

Back grinding

Side grinding



Walter - Machine

Walter

12V9-22°

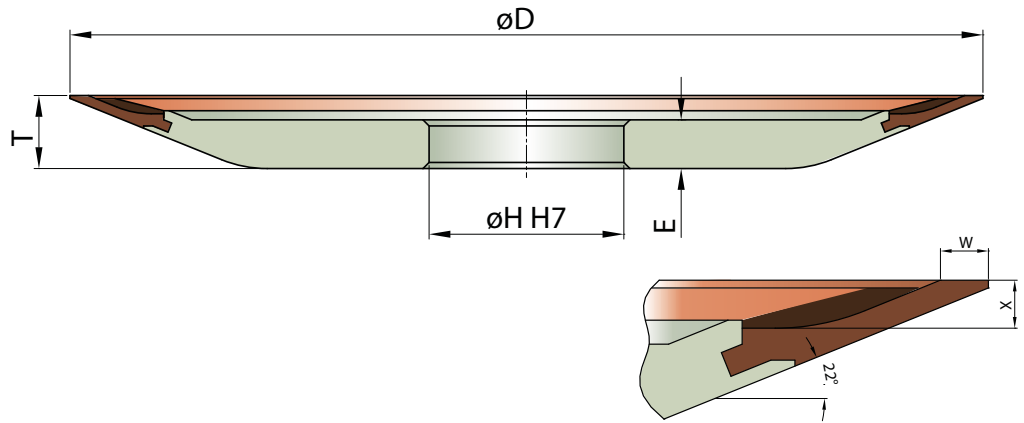

Shape	D	W	X	H	T	E	Machinetype
12V9-22°	150	3	3	32	12	8	NC2, NC3, NC4

Order specimen:

Shape	Dimension	Quality
12V9-22°	D-W-X-H: 150-3-3-32	D64 R125 BW361 Y A

Walter

12V9-22°

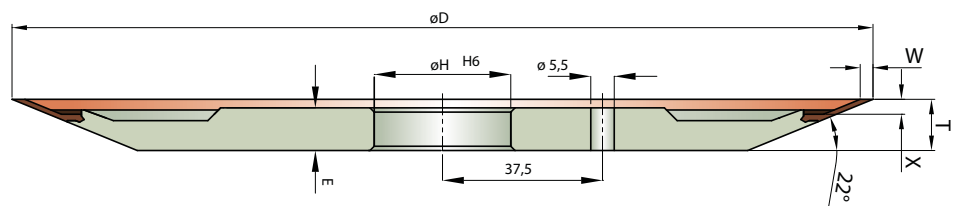

Shape	D	W	X	H	T	E	Machinetype
12V9-22°	200	3	3	32	12	10	CNC5

Order specimen:

Shape	Dimension	Quality
12V9-22°	D-W-X-H: 200-3-3-32	D64 R125 BW361 Y A



Walter

4B9-832

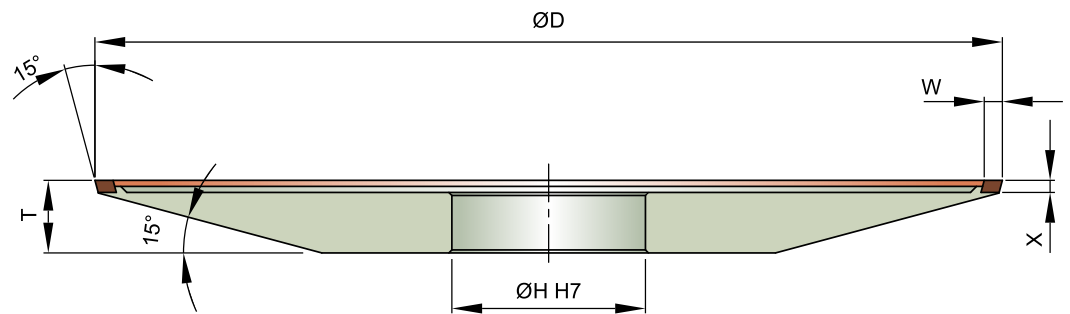

Shape	D	W	X	H	T	Machinetype
4B9-832	150	3	2	32	12	NC2, NC3, NC4

Order specimen:

Shape	Dimension	Quality
4B9-832	D-W-X-H: 150-3-2-32	D64 R125 BW361 Y A

Walter

4V2-842
4V2-S42

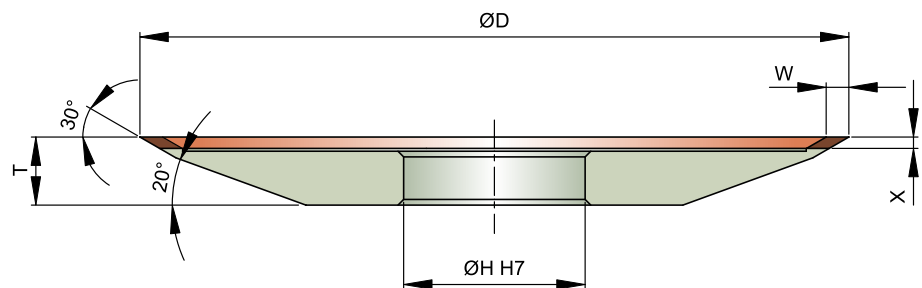

Shape	D	W	X	H	T	E	Machinetype
4V2-842	150	4	2	32	13	11	NC2, NC3, NC4
4V2-S42	160	4	2	32	13	11	NC3, C5

Order specimen:

Shape	Dimension	Quality
4V2-842	D-W-X-H: 150-4-2-32	D76 R125 BW361 Y A



Walter

4V2-042

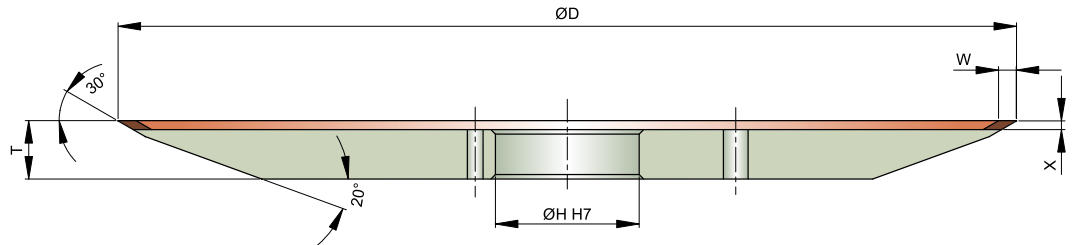

Shape	D	W	X	H	T	Machinetype
4V2-042	200	4	2	32	13	CNC5

Order specimen:

Shape	Dimension	Quality
4V2-042	D-W-X-H: 200-4-2-32	D76 R125 BW361 Y A

Walter

1A8W

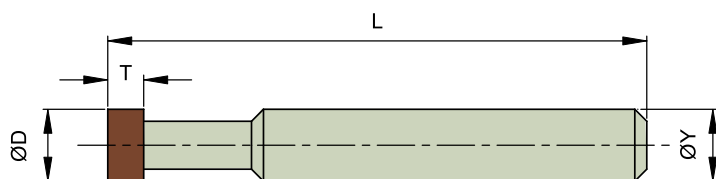

Shape	D	T	X	Y	L
1A8W	6.5	3	1.75	6	45
1A8W	6.5	6	1.75	6	48

Order specimen:

Shape	Dimension	Quality
1A8W	D-T-X-Y: 6.5-3-1.75-6	D64 R125 BW361 Y E

Walter

14B1-858
14B1-058

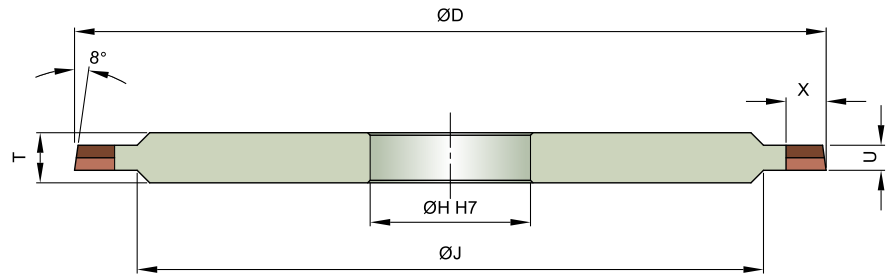

Shape	D	U	X	H	T	J	Machinetype
14B1-858	150	5	8	32	10	125	NC3, NC4, CNC5, C5
14B1-058	200	5	8	32	10	175	CNC 5

Order specimen:

Shape	Dimension	Quality
14B1-858	D-U-X-H: 150-5-8-32	D126/46 R100/75 BW360 Y I/BW360 Y I

Walter

62B9-545
62B9-645

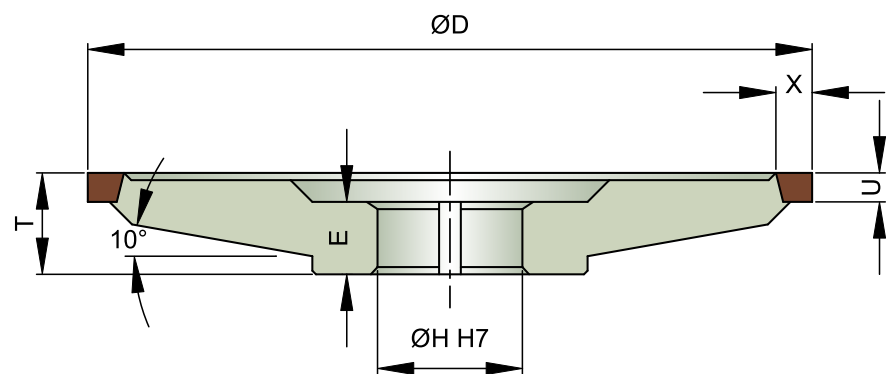

Shape	D	U	X	H	T	E
62B9-545	75	4	5	20	14	10
62B9-645	100	4	5	20	14	10

Order specimen:

Shape	Dimension	Quality
62B9-645	D-U-X-H: 100-4-5-20	D91 R75 BW356 Y A

Back grinding

Side grinding



Weinig - Machine

Weinig

14F1-025
14F1-035
14F1-046

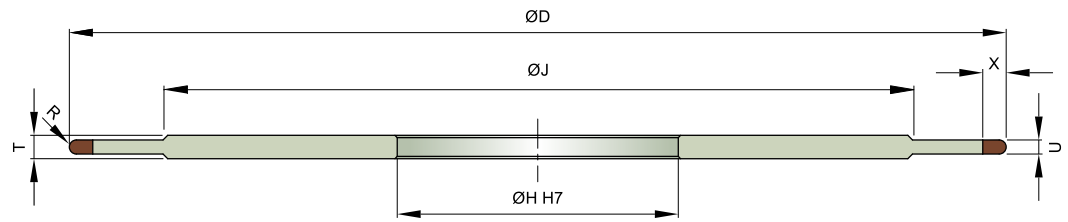

Shape	D	U	X	H	T	R	J
14F1-025	200	2	5	60	5	U/2	145
14F1-035	200	3	5	60	5	U/2	145
14F1-046	200	4	6	60	5	U/2	145

Order specimen:

Shape	Dimension	Quality
14F1-025	D-U-X-H: 200-2-5-60	D91 RB76 A

Weinig

14A1-025
14A1-035

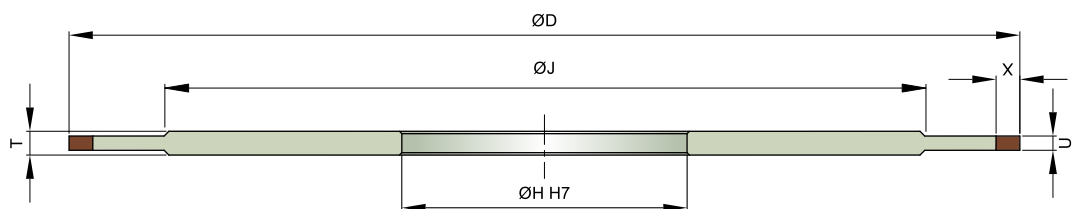

Shape	D	U	X	H	T	J
14A1-025	200	2	5	60	5	145
14A1-035	200	3	5	60	5	145

Order specimen:

Shape	Dimension	Quality
14A1-025	D-U-X-H: 200-2-5-60	D91 R100 BW185 N A



Weinig

4A2-823

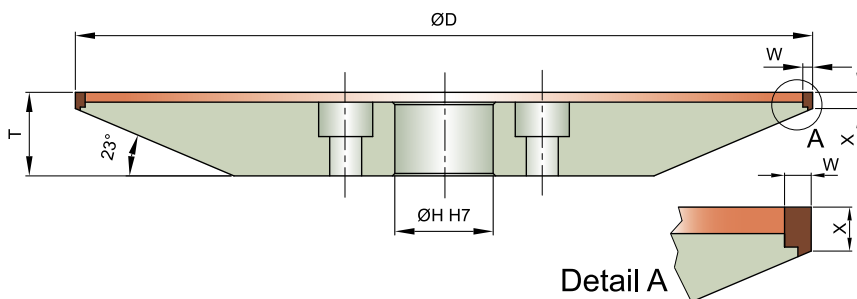

Shape	D	W	X	H	T
4A2-823	150	2	3.3	20	17

Order specimen:

Shape	Dimension	Quality
4A2-823	D-W-X-H: 150-2-3.3-20	D91 R100 BW185 N A

Weinig

6A2-734

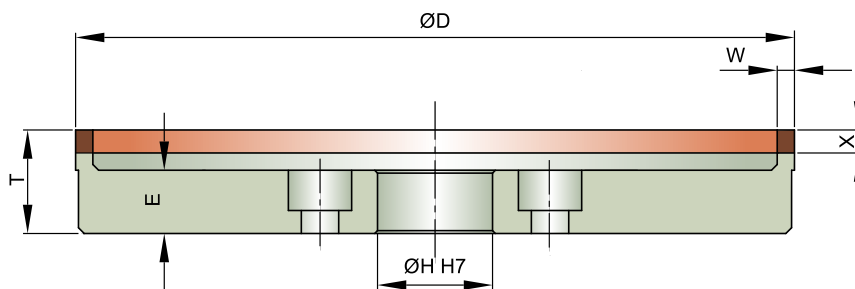

Shape	D	W	X	H	T	E
6A2-734	125	3	4	20	18	11

Order specimen:

Shape	Dimension	Quality
6A2-734	D-W-X-H: 125-3-4-20	D76 R75 BW351 Y A



Iseli



1CH1

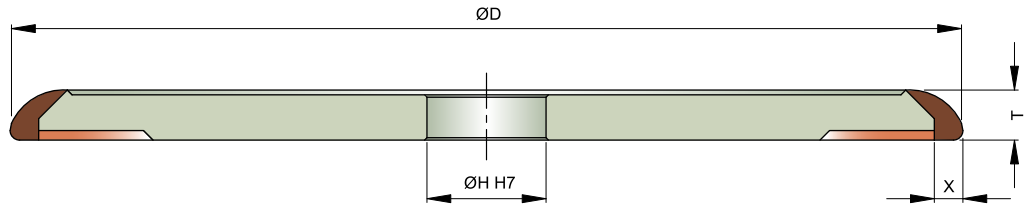

Shape	D	T	X	H
1CH1	200	10.5	6	20
1CH1	200	10.5	6	25
1CH1	200	10.5	6	32
1CH1	250	10.5	6	20
1CH1	250	10.5	6	25
1CH1	250	10.5	6	32

Order specimen:

Shape	Dimension	Quality
1CH1	D-T-X-H: 200-10.5-6-25	B151 R100 BT371 Y A

Iseli

3CH1

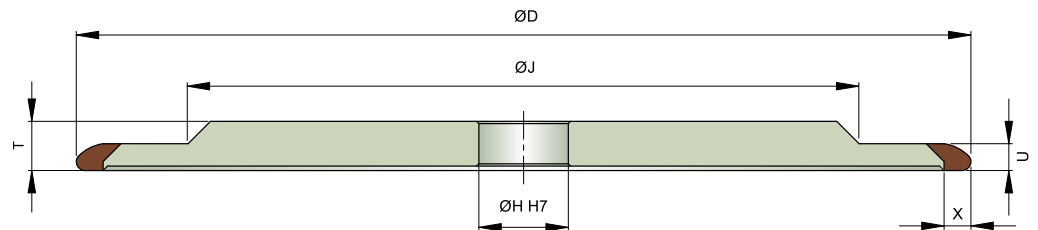

Shape	D	U	X	H	T	J
3CH1	200	6	6	20	11	140
3CH1	200	6	6	25	11	140
3CH1	200	6	6	32	11	140
3CH1	250	6	6	20	11	190
3CH1	250	6	6	25	11	190
3CH1	250	6	6	32	11	190

Order specimen:

Shape	Dimension	Quality
3CH1	D-U-X-H: 200-6-6-25	B151 R100 BT371 Y A



Iseli



Tooth shape grinding

3V1-40°

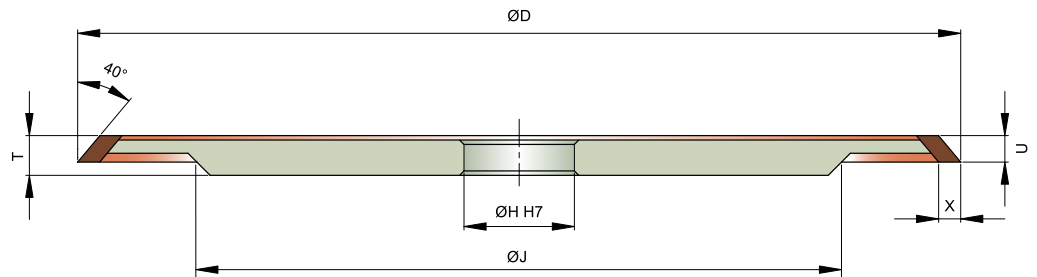

Shape	D	U	X	H	T	J
3V1-40°	200	6	5	25	9	140

Order specimen:

Shape	Dimension	Quality
3V1-40°	D-U-X-H: 200-6-5-25	D91 P100 BW351 Y A

Iseli

6A9

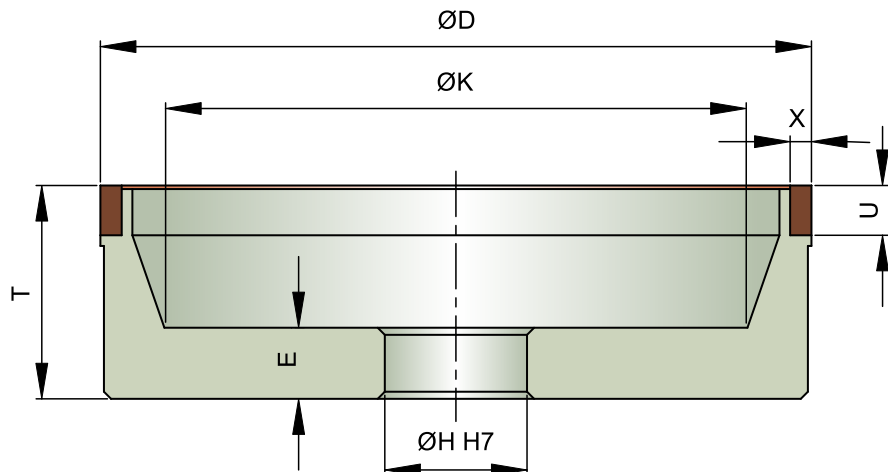

Shape	D	U	X	H	T	E	K
6A9	100	7	3	20	30	10	82
6A9	100	10	3	20	30	10	82

Order specimen:

Shape	Dimension	Quality
6A9	D-U-X-H: 100-7-3-20	B151 R75 BT956 Y A

Our wheels are successfully used worldwide in the following branches.



Industrial branches

Aviation Industry
Aerospace Industry
Automotive Industry
Rail Industry
Engine Industry
Shipbuilding Industry
Machine Building Industry
Mining Industry
Oil Industry
Paper Industry
Healthcare Industry

Metalworking and
Processing Industry





we shape your world

www.molemab.com

PRODUCTION UNITS

molemab SpA
via Provinciale 10
25050 Ome (Brescia)
ITALY
tel +39 030 6859888
fax +39 030 652010
molemab@molemab.com

Maclodio facility
via XXV aprile 15
25030 Maclodio (Brescia)

molemab Inotech
Schleifmittelindustrie GmbH
Hauptstrasse 17
9314 Launsdorf
AUSTRIA
tel +43 4213 4120
fax +43 4213 4120 - 20
office@molemab.at

molemab USA Corp.
150 Kendall Point Drive
Oswego Illinois 60543
USA
tel +1 800 962 2226
sales@molemab.com

COMMERCIAL BRANCHES

molemab super-abrasifs France Sas
2, rue A. Fresnel (Parc d'activité Le Fresnel I)
69680 Chassieu
FRANCE
tel +33 (0)4 72 21 82 39
fax +33 (0)4 72 50 58 11
superabrasifs@molemab.com

molemab Iberica SLU
Poligono Industrial Sur (CC/Les Forques, 13-15)
08754 El Papiol (Barcelona)
SPAIN
tel +34 93 67 30 562
fax +34 93 67 30 563
molemab@molemab.es

molemab GmbH
Maria-Merian-Str. 10
85521 Ottobrunn
GERMANY
tel +49 89 6328620 0
fax +49 89 6328620 20
molemabgermany@molemab.com

molemab Abrasives Ungheria kft
Váci Utca 81. IV.em
1056 Budapest
HUNGARY
tel +36 70-524-23-14
molemabhungary@molemab.com

molemab Canada
2141 rue Nobel, Suite 104
J3E1Z9 Sainte-Julie - QC
CANADA
tel +1 450 338 4241
fax +1 450 338 4291
sales@molemab.com

molemab USA Corp.
91 Carey Road
12804 Queensbury - NY
USA
tel +1 800 962 2226
fax +1 888 203 3876
sales@molemab.com

Primex Abrasives USA
91 Carey Road
12804 Queensbury - NY
USA
tel +1 800 333 0210 and +1 450 338 4353
fax +1 800 394 1732 and +1 450 338 4374
sales@primextools.com
www.primexabrasives.com

molemab México SA de CV
Acceso B 102-A numero 202
Zona Industrial Jurica
76100 Querétaro
MEXICO
tel +52 442 321 2799
molemab@molemab.mx

Office Poland
43-200 Pszczyna
ul. Bogedaina 5
POLAND
tel +48 502 548 844
office.poland@molemab.com

Office China
Ledu building, Ledu road
Songjiang zone, Shanghai
CHINA
tel +013917879667
office.china@molemab.com



www.molemab.com

